

**Technical Specifications (In-Cash Procurement)**

**Technical specification - Integration and interface  
management of the Tokamak Assembly Preparation  
Building**

Technical specification - Integration and interface management of the Tokamak Assembly  
Preparation Building

## Table of Contents

<b>1</b>	<b>PURPOSE</b> .....	<b>2</b>
<b>2</b>	<b>SCOPE OF WORK</b> .....	<b>2</b>
2.1	Tokamak Assembly Preparation Building (TAPB).....	2
2.2	Scope of work.....	7
<b>3</b>	<b>DEFINITIONS AND ACRONYMS</b> .....	<b>7</b>
<b>4</b>	<b>ESTIMATED DURATION</b> .....	<b>8</b>
<b>5</b>	<b>WORK DESCRIPTION</b> .....	<b>8</b>
5.1	Context .....	8
5.2	Objective of the contract .....	8
5.2.1	Requirement of TAPB 1 .....	8
5.2.2	Update and completion of the functional analysis and Integrated Logistics Support Plan 9 .....	9
5.2.3	Update and completion of the process within the TAPB .....	9
5.2.4	Update and completion of the ICD and IS .....	9
5.2.5	Safety demonstration versus design features sequence .....	10
5.2.6	Lessons learned and feedback from TAPB .....	10
<b>6</b>	<b>RESPONSIBILITIES</b> .....	<b>10</b>
6.1	Contractor’s Responsibilities .....	10
6.2	IO’s Responsibilities .....	10
<b>7</b>	<b>LIST OF DELIVERABLES AND DUE DATES</b> .....	<b>11</b>
<b>8</b>	<b>ACCEPTANCE CRITERIA</b> .....	<b>13</b>
<b>9</b>	<b>SPECIFIC REQUIREMENTS AND CONDITIONS</b> .....	<b>13</b>
<b>10</b>	<b>WORK MONITORING / MEETING SCHEDULE</b> .....	<b>13</b>
<b>11</b>	<b>DELIVERY TIME BREAKDOWN</b> .....	<b>14</b>
<b>12</b>	<b>QUALITY ASSURANCE (QA) REQUIREMENTS</b> .....	<b>14</b>
<b>13</b>	<b>CAD DESIGN REQUIREMENTS (IF APPLICABLE)</b> .....	<b>14</b>
<b>14</b>	<b>SAFETY REQUIREMENTS</b> .....	<b>14</b>
<b>15</b>	<b>APPENDIX 1: MAIN FEATURES OF THE TAP BUILDING AND THE TAPB WORKSHOP</b> .....	<b>16</b>

# 1 Purpose

This document aims at specifying the sub-contracted activities to be performed for the Tokamak Assembly Preparation Building (TAPB):

- 1 – Update and completion of TAPB requirement,
- 2 – Functional analysis, operation and maintenance plan of the TAPB,
- 3 – Management of interfaces, in particular the update and completion of the Interface Control Documents and Interface Sheets,
- 4 – Safety compliance matrix and lessons learned,
- 5 – Support the preparation of the DIR and SDR.

## 2 Scope of work

### 2.1 Tokamak Assembly Preparation Building (TAPB)

The functions of the Tokamak Assembly Preparation Building are listed below:

#### 1 - To transfer storage containers

- To Import / Export beryllium storage containers
- To transfer beryllium storage containers within the building

#### 2 - To store containers of Beryllium First Wall (FW)

#### 3 - To Perform the Trial Fit

- To buffer store a few Shield Blocks (6)
- To unwrap FW and SB from their storage containers
- To perform smear tests of the Beryllium surface contamination
- To tilt / upend the FW and to transfer it
- To decontaminate if contamination is too high
- To perform metrology tests
- To assemble FW to SB

The layout of the building is the following:

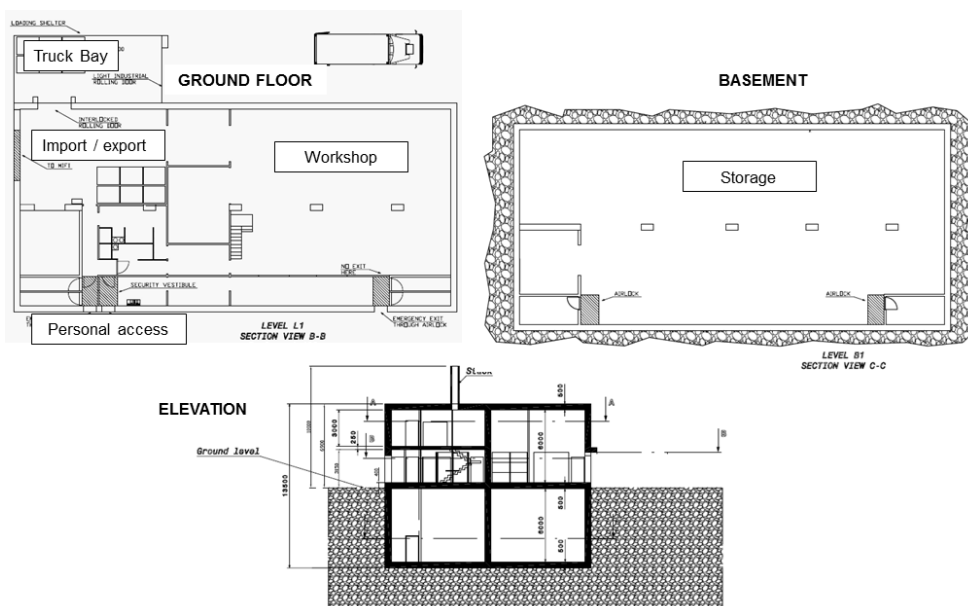

Figure 1 Plan view and elevation of the TAP Building

The overview of the conceptual design is given at the following link:

[ITER\\_D\\_UZWSWY - 0 TAP Building - Overview of the conceptual design](#)

Appendix 1 give illustration of the main feature at ground floor and basement level.

The TAPB will have two functions corresponding to two phases of activity (see *Figure 2*):

- Phase 1: Support to Tokamak Installation from 2020 to 2024,
- Phase 2: Support to perform the Beryllium First Wall (Be FW) trial fits and storage of the Be FWs, from 2025 to 2028,

This affords the opportunity to deliver the facility using a staged approach (see *Figure 2*):

- Phase 1 works (pre-beryllium) are the building external envelope, lift, doors and building services limited to those needed for Phase1 warehouse function. During this period, the facility shall be flexible enough to house different types of needs for Assembly,

The description of the Phase 1 activities and requirements are given in this section.

- Phase 2 works (beryllium) are the reception, the transfer, the storage and the trial fit of First Wall (FW) panels with Shield Blocks (SB).

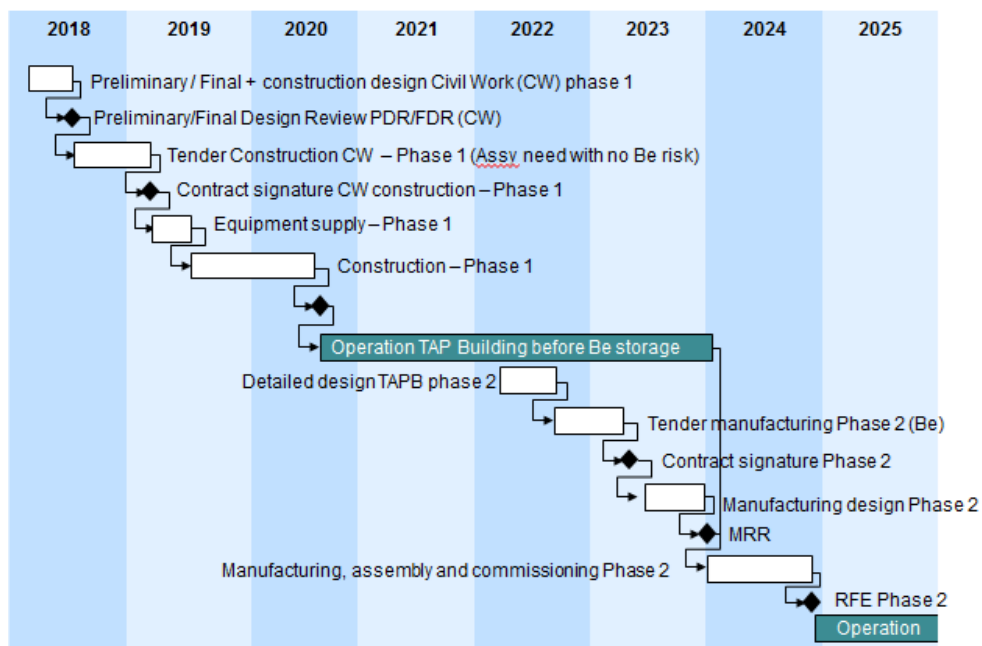

Figure 2 : Preliminary schedule of design, construction and operation

The TAPB configuration during phase 1 works is called TAPB1.

The TAPB configuration during phase 2 works is called TAPB2.

The Tokamak Assembly Preparation Building (TAPB) shall be located within the ITER site boundary. It shall provide a suitable environment for the systems and workers inside.

The TAPB is a substantial stand-alone concrete building with one basement level, a ground level and a mezzanine (mezzanine only in phase 2).

The footprint is approximately 41 m x 17 m (without the steel frame import/export facility), i.e. approximately 700 m<sup>2</sup>, the basement extends approximately 6.2 m below ground and the main floor of the building rises approximately 7 m above site ground.

TAPB1 shall house miscellaneous needs to support the Assembly of the Tokamak, with no nuclear safety requirement, except for the “non-reversible” parts (e.g. CW or lift).

TAPB2 shall house, support and provide space and systems to receive, transport, test, store, pre-assemble and export components consisting of Berylliated components during the Assembly phase of the Tokamak.

To be noted that in line with the ITER decree, Be is considered as a hazardous substance. Therefore, it shall be confined with two systems, based on two confinement methods: static and dynamic.

The structure of the TAPB shall provide space for the systems that they contain and enough strength to support itself, the components, all necessary assembly tooling and equipment and the building systems.

The TAPB is located within the INB Perimeter, on the North-East corner of Area 73. Site view is given in Figure 3.

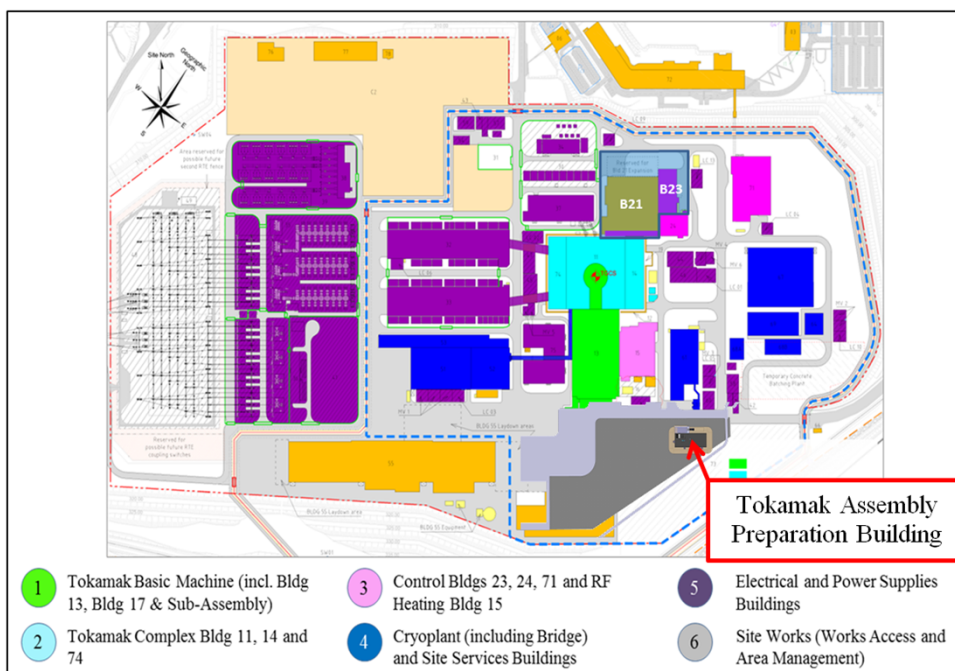

**Figure 3 : Preliminary location of the TAPB on the site master plan**

The 3D outline drawings below (Figure 4 and 5) are extracted from the conceptual design made end of 2017.

**Phase 1: TAP1 for Assembly needs**

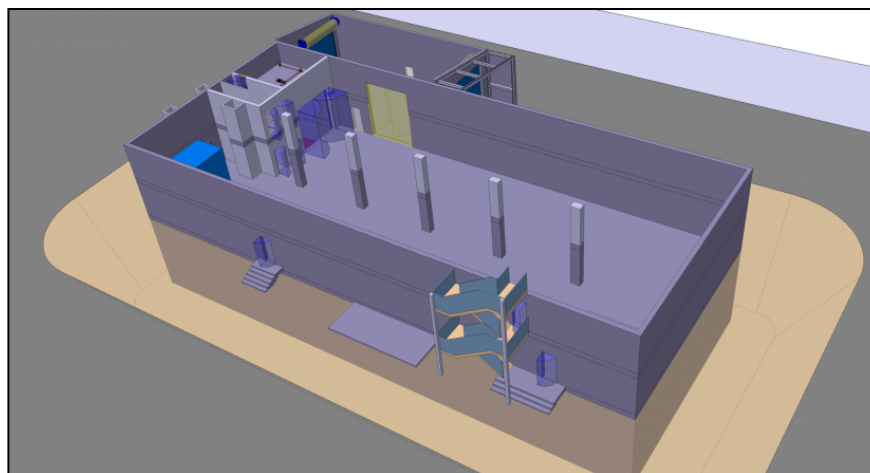
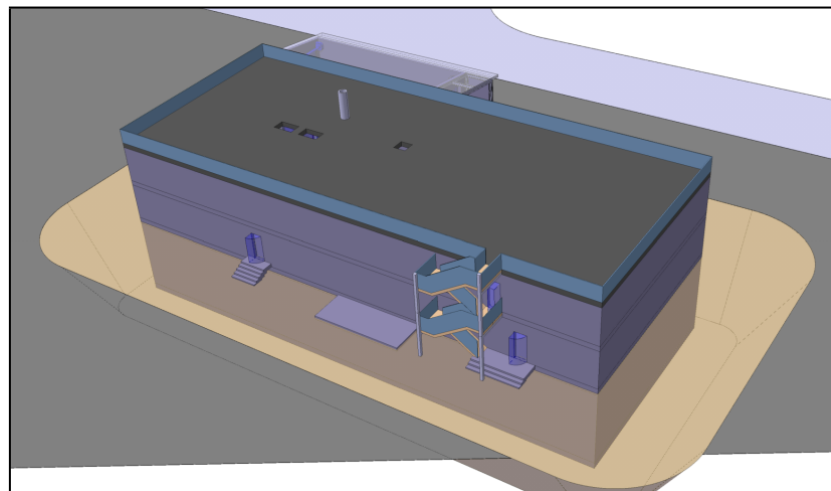
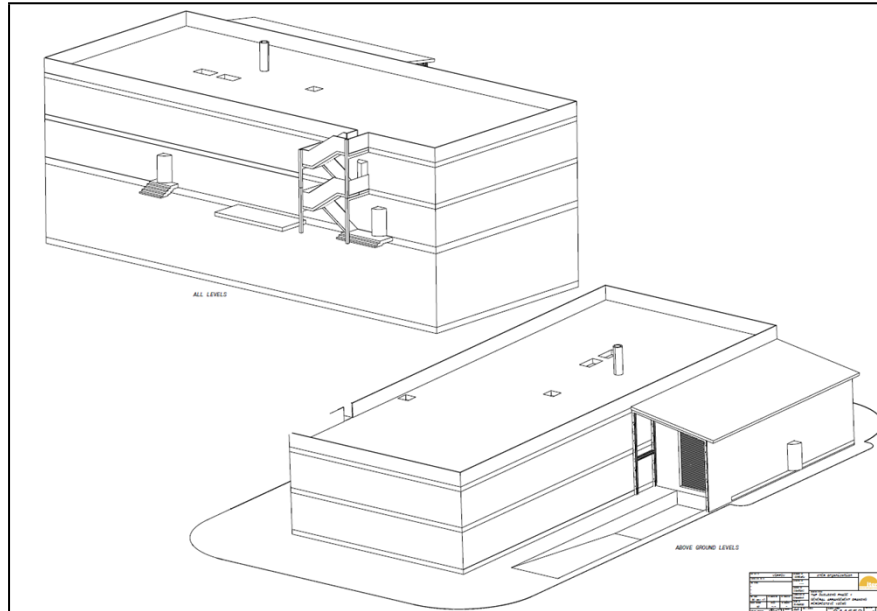

**Figure 4 : 3D outline of TAPB1**

**Phase 2: TAPB2 for Be FW storage/trial**

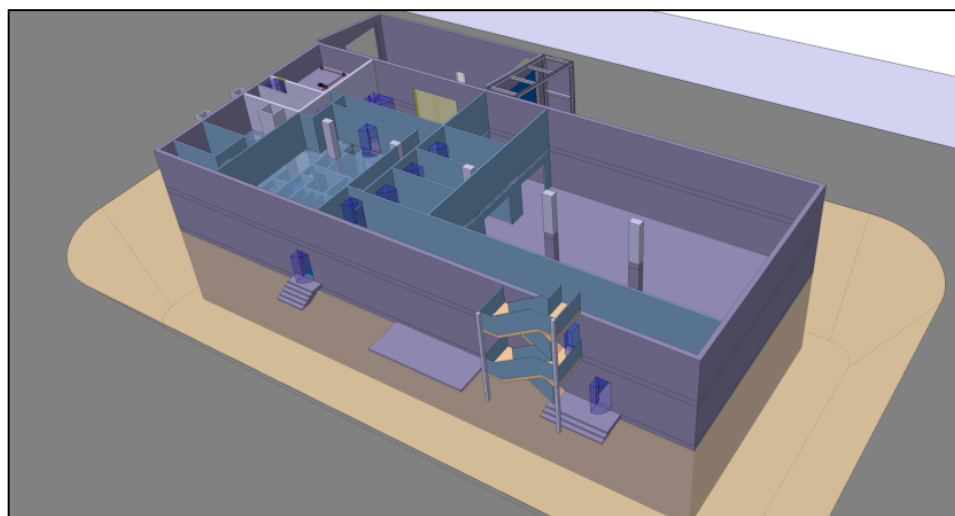
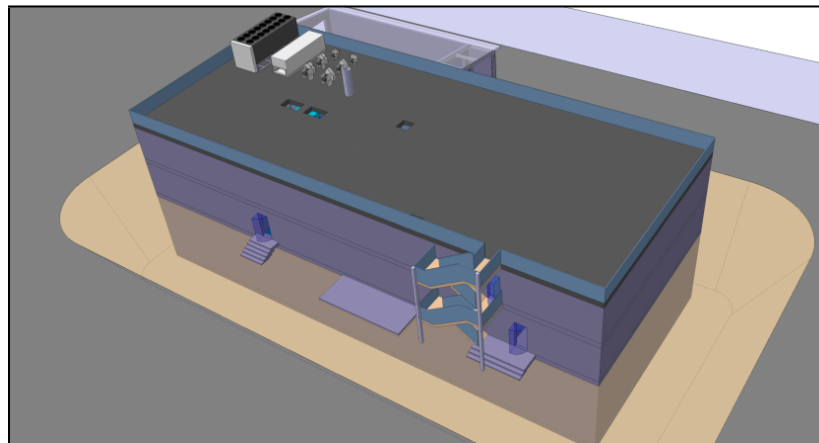
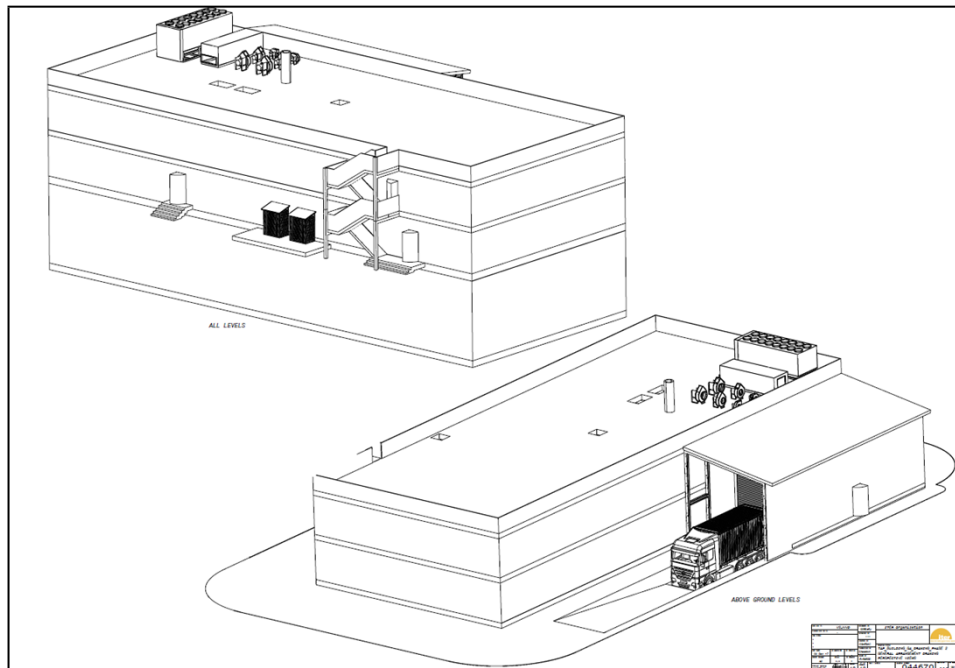

**Figure 5 : 3D outline of TAPB2**

## 2.2 Scope of work

The scope of work corresponds to:

- The update and refinement of the TAPB requirement and interfaces for the first phase of operation: TAPB1,
- The update and completion of the functional analysis TAPB1 and TAPB2,
- The update and completion of the process within the TAPB: reception, transfer, storage and operation in the workshop, in particular the leak test, measurements and trials fits between shield blocks and blanket first wall. This analysis includes:
  - o the logistic analysis,
  - o draft procedures,
  - o identification of space, utilities and services requested to perform the operations,
- The update and completion of the ICD and IS between all PBS involved in TAPB activities, in particular building interfaces,
- To support the preparation of the documentation for DIR and SDR,
- Tracking of inter relationship between safety demonstration and design features of the TAPB2, in particular versus Be contamination risk, fire risk and other internal hazard. It corresponds in particular to a formal compliance matrix,
- Lessons learned and feedback from TAPB design activities to Hot Cell Complex design activities for the Be phase,

## 3 Definitions and acronyms

- BM: Blanket Module
- C-R: Contractor Responsible. See Contract specifications for definition of duty.
- C-TRO: Contractor Task Responsible Officer. See Contract specifications for definition of duty.
- DIR: Design Integration Review
- EP: Embedment Plate
- FDR: Final Design review
- FW: First Wall
- IO-RO: ITER Organization Responsible Officer. See Contract specifications for definition of duty
- IO-TRO: ITER Organization Task Responsible Officer. See Contract specifications for definition of duty
- ICS: Interface Control Document
- IS: Interface Sheet
- PDR: Preliminary Design Review
- PBS: Project Breakdown Structure
- SB: Shield Block
- SDR: System Design Review
- TAPB: Tokamak Assembly Preparation Building



For a complete list of ITER abbreviations see: [ITER Abbreviations \(ITER\\_D\\_2MU6W5\)](#).

## 4 Estimated Duration

The contract duration shall be one year and shall commence after the official start date and upon the mutual agreement of both parties.

## 5 Work Description

### 5.1 Context

Conceptual design activities of the TAPB have been performed end of 2017.

The activities and expected deliverables shall correspond to two phases:

- 1 – the design activities of the TAPB in 2018, aiming at reaching the design reviews and achieving a sufficient level of maturity before launching the construction contract,
- 2 – the tender documentation and the tender process of the construction contract end of 2018/early 2019.

The work to be performed corresponds to these two phases of TAPB activities and they correspond to the scope of work defined in section 2.2.

The services shall be performed on-site at IO.

### 5.2 Objective of the contract

The objective of the contract is broken down into 6 types of activities which are described below, in line with the requirements of [ITER\\_D\\_4CK4MT - ITER System Design Process \(SDP\) Working Instruction](#), keeping in mind that the objectives is to perform a merged PDR/FDR of TAPB at T0+6 months, with a PDR maturity level for TAPB2 and FDR maturity level for TAPB1.

#### 5.2.1 Requirement of TAPB 1

During the first phase of operation (see *Figure 2*), the facility shall be flexible enough to house different types of needs, as for illustration:

- Support Vacuum Laboratory,
- Magnet Infrastructure Facilities for ITER (MIFI 2),
- In-vessel Mock-ups and Trials Facility.

The objective is to update and to complete the existing requirement document [ITER\\_D\\_JE4J89 - TAPB Phase 1 Design Inputs to the TAPB design](#) aiming at providing the requirement for TAPB1.

### *5.2.2 Update and completion of the functional analysis and Integrated Logistics Support Plan*

The preliminary functional analysis was presented at the CDR, it shall be updated and completed for TAPB1 and TAPB2 configuration, in a consistent way with the interfaces (ICD and IS – see section 5.2.4).

In the same way, an Integrated Logistics Support Plan is to be written. This shall include a preliminary version of the operation plan (including human factor aspects), the maintenance plan, the Periodic Test and Inspections Plans. The expected maturity level is preliminary for TAPB2 and complete for TAPB1 configuration (see [ITER\\_D\\_4CK4MT - ITER System Design Process \(SDP\) Working Instruction](#)).

### *5.2.3 Update and completion of the process within the TAPB*

This activity corresponds to the update and completion of the process within the TAPB:

- reception,
- transfer,
- storage,
- measurement and characterization in the laboratory (new function to be added),
- operation in the workshop, in particular the leak test, measurements and trials fits between shield blocks and blanket first wall.

This analysis includes:

- the logistic analysis,
- the identification of space, utilities and services requested to perform the operations.
- The Human and Organizational Factor and Ergonomics requirements related with the process within the TAPB

This activity corresponds to the update and completion of the document [ITER\\_D\\_VJHSYG - Assembly procedure and tool requirement of the TAPB workshop](#), in close relation with the mechanical design which will be performed on the workstations, the storage containers of the FWs and the storage racks.

### *5.2.4 Update and completion of the ICD and IS*

This activity corresponds to the update and completion of ICD and IS between PBS.

It shall include all ICD and IS related to TABP activities, with a summary interface matrix.

Specific attention shall be paid to the interfaces between PBS62-22 (building) and the other PBS, such as the following ones:

- [ITER\\_D\\_VNXDT5 - ICD-22-62.22 ICD for trial fits workshop in TAPB](#)
- [ITER\\_D\\_VNUWK8 - ICD-16-62.22 Interface Control Document for Blanket System \(PBS 16\) and Tokamak Assembly Preparation Building Systems \(PBS 62.22\)](#)
- [ITER\\_D\\_VPELNZ - ICD-43-62.22 ICD for TAPB and Steady State Electrical Power](#)
- [ITER\\_D\\_VPEPQ9 - ICD-44-62.22 ICD for TAPB Cable trays](#)
- [ITER\\_D\\_VSFAZ4 - ICD-45-62.22 ICD for CODAC and TAP Building](#)
- [ITER\\_D\\_VPETDU - ICD-48-62.22 ICD for TAPB and Central Safety System](#)

- [ITER\\_D\\_VPEUB5 - ICD-62.22-64 ICD between TAPB and Radiological & Environmental Monitoring](#)
- [ITER\\_D\\_VP4CFW - ICD-62.22-65 ICD for TAPB and Liquid and Gas Distribution](#)
- [ITER\\_D\\_2EPRNT - ICD-62.21-66 Interface Control Document for Hot Cell Building \(PBS 62-21\) and Radwaste Treatment & storage \(PBS 66\)](#)
- [ITER\\_D\\_VPEGYX - ICD-62.22-69 ICD for TAPB and Access Control and Security](#)

Illustration of other Interfaces between different PBS: [ITER\\_D\\_4DA2YU - ICD-16-64 Interface Control Document for Blanket System \(PBS 16\) and Radiological and Environmental Monitoring System \(PBS 64\)](#)

After the PDR/FDR, specific attention shall be paid to the interfaces with the site: IS and description of functional and physical interfaces with the site networks, e.g. drainage, power supply, control, alarm, liquid and gas.

### 5.2.5 *Safety demonstration versus design features sequence*

The safety demonstration is presented at the following link: [ITER\\_D\\_UZWSWY - 0 TAP Building - Overview of the conceptual design](#)

Goal of this activity is:

- to check that during the design process, the design is based on the safety requirement coming from the safety analysis and vice versa,
- to keep track of the safety requirement based on a safety compliance matrix.

### 5.2.6 *Lessons learned and feedback from TAPB*

Goal of this activity is to keep record of lessons learned and feedback from TAPB design activities to Hot Cell Complex design activities for the Be phase, in particular the safety principles, threshold values and any lessons learned that will need to be kept in mind for the design of the Hot Cell Complex during the Be phase.

## 6 Responsibilities

### 6.1 Contractor's Responsibilities

In order to successfully perform the tasks in these Technical Specifications, the Contractor shall:

- Strictly implement the IO procedures, instructions and use templates;
- Provide experienced and trained resources to perform the tasks;
- Contractor's personnel shall possess the qualifications, professional competence and experience to carry out services in accordance with IO rules and procedures;
- Contractor's personnel shall be bound by the rules and regulations governing the IO ethics, safety and security IO rules.

## 6.2 IO's Responsibilities

The IO shall:

- Nominate the Responsible Officer to manage the Contract;
- Organise weekly meetings on work performed;
- Provide offices at IO premises;
- Provide a standardized IT working environment (laptop, screen, keyboard, webcam and headset);

## 7 List of deliverables and due dates

The list of deliverables corresponds to the activities defined in section 2.2 and detailed in section 5.2, adapted to the schedule of the project (see *Figure 2*).

D #	Description	Due Dates
D1	<u>PDR/FDR documentations (step 1):</u> <ul style="list-style-type: none"> <li>- First update of TAPB1 requirements (see section 5.2.1),</li> <li>- First update of functional analysis TAPB1 and TAPB2 (see section 5.2.2),</li> <li>- Update of ICD and matrix of interfaces between PBSs (see section 5.2.4),</li> </ul>	T0 + 2 months
D2	<u>PDR/FDR documentations (step 2):</u> <ul style="list-style-type: none"> <li>- Second update of TAPB1 requirements (see section 5.2.1),</li> <li>- Second functional analysis and preliminary version of the SLI documents (see section 5.2.2),</li> <li>- First update of the TAPB process analysis (see section 5.2.3),</li> <li>- TAPB interfaces: update of ICD and Preliminary version of IS (see section 5.2.4),</li> </ul>	T0 + 4 months

D #	Description	Due Dates
D3	<u>PDR/FDR documentations (step 3):</u> <ul style="list-style-type: none"> <li>- Complete version of the TAPB1 requirements (see section 5.2.1),</li> <li>- Complete version of the functional analysis and SLI documents for the PDR/FDR (see section 5.2.2),</li> <li>- Complete version of the TAPB process analysis (see section 5.2.3),</li> <li>- Complete version of the TAPB interfaces (see section 5.2.4),</li> <li>- Preliminary version of the safety compliance matrix (design vs safety requirement – see section 5.2.5)</li> </ul>	T0 + 6 months
D4	<u>Tender documentations and safety analysis (step 1):</u> <ul style="list-style-type: none"> <li>- Updated version of the documents issued for D3 at T0+6 months, in order to take into account the outcome of the FDR/PDR (see section 5.2.1 to 5.2.4),</li> <li>- Detailed Interfaces Sheets between the TAPB and the site (see section 5.2.4),</li> </ul>	T0 + 8 months
D5	<u>Tender documentations and safety analysis (step 2):</u> <ul style="list-style-type: none"> <li>- Updated version of the safety compliance matrix taken into account the outcome of the PDR/FDR (design vs safety requirement – see section 5.2.5)</li> <li>- Preliminary TAPB lessons learned (see section 5.2.6),</li> </ul>	T0 + 10 months
D6	<u>Tender documentations and safety analysis (step 3):</u> <ul style="list-style-type: none"> <li>- Completed version of the safety compliance matrix (design vs safety requirement – see section 5.2.5)</li> <li>- Complete version of the document summarizing TAPB lessons learned for HCC design activities (see section 5.2.6),</li> </ul>	T0 + 12 months

To be noted that:

- An important part of this activity relies on the ability to work in a close and collaborative way with other teams, such as the team in charge of the Blanket Modules (and likely with the DAs in charge of the BM procurement), the Assembly team, the building team and the safety team. The contractor shall prepare, as appropriate, support for technical meetings, aiming at finding technical agreements between all involved parties, keeping in mind the overall cost optimization of the systems being designed.

- The priorities between the different Deliverables to be issued could be changed at the KoM or during the duration of the contract, as per IO request and in agreement with the contractor.
- Each of the deliverables D1 to D6 shall provide the IDM links of the documents being elaborated during the given period, as described in the table of deliverables above and according to the description given in section 5.2.

## 8 Acceptance Criteria

These criteria shall be the basis of acceptance by IO following the successful completion of the services. These will be in the form of monthly progress reports as indicated in section 7, table of deliverables and further detailed below:

- Reports as deliverables shall be stored in the ITER Organization's document management system, IDM by the Contractor for acceptance.
- Technical Responsible Officer is the Approver of the delivered documents.
- The Approver can name one or more Reviewers(s) in the area of the report's expertise.
- The Reviewer(s) can ask modifications to the report in which case the Contractor must submit a new version.
- The acceptance of the document by the Approver is the acceptance criterion.
- The acceptance criteria of the document correspond to:
  - Justified and documented comments,
  - Lessons learned of existing nuclear facilities,
  - Reference to existing technologies and proven solutions used in nuclear field,
  - Reference to existing and applicable Norms and Standards,

## 9 Specific requirements and conditions

The contractor shall have significant experience in the following areas:

- In the design of nuclear facility, dealing with chemical or radioactive contamination risks.
- In management of interfaces in complex nuclear projects, in particular building interfaces.
- In nuclear safety.
- In functional analysis, operational and maintenance procedures.
- In commissioning and operation of nuclear facilities.

The contractor shall also provide with their offer:

- a resource loaded schedule, in line with the delivery dates given in section 7,
- a resource estimate for each of the Deliverables,

## 10 Work Monitoring / Meeting Schedule

The work will be managed by means of Progress Meetings and/or formal exchange of documents transmitted by emails which provide detailed progress. Progress Meetings will be called by the ITER Organization, to review the progress of the work, the technical problems and the planning. It is expected that Progress Meetings will be held weekly or biweekly. Progress meetings will involve C-R, CTROs, IO-RO and IO-TROs.

The main purpose of the Progress Meetings is to allow the ITER Organization/RHRM Division and the Contractor Technical Responsible Officers to:

- a) Allow early detection and correction of issues that may cause delays;
- b) Review the completed and planned activities and assess the progress made;

- c) Permit fast and consensual resolution of unexpected problems;
- d) Clarify doubts and prevent misinterpretations of the specifications.

In addition to the Progress Meetings, if necessary, additional meetings to address specific issues to be resolved may be requested by the ITER Organization.

For all Progress Meetings, a document (the Progress Meeting Report) describing tasks done, results obtained, blocking points and action items must be written by the Contractor. Each report will be stored in the ITER IDM in order to ensure traceability of the work performed.

## **11 Delivery time breakdown**

See Section 7 – Deliverables and Due Date

## **12 Quality Assurance (QA) Requirements**

The organisation conducting these activities should have an ITER approved QA Program or an ISO 9001 accredited quality system.

The general requirements are detailed in [ITER Procurement Quality Requirements \(ITER\\_D\\_22MFG4\)](#).

Prior to commencement of the task, a Quality Plan must be submitted for IO approval giving evidence of the above and describing the organisation for this task; the skill of workers involved in the study; any anticipated sub-contractors; and giving details of who will be the independent checker of the activities (see [Procurement Requirements for Producing a Quality Plan \(ITER\\_D\\_22MFMW\)](#)).

Documentation developed as the result of this task shall be retained by the performer of the task or the DA organization for a minimum of 5 years and then may be discarded at the direction of the IO. The use of computer software to perform a safety basis task activity such as analysis and/or modelling, etc. shall be reviewed and approved by the IO prior to its use, in accordance with [Quality Assurance for ITER Safety Codes \(ITER\\_D\\_258LKL\)](#).

## **13 CAD Design Requirements (if applicable)**

Not applicable, no CAD design activity is requested.

## **14 Safety requirements**

ITER is a Nuclear Facility identified in France by the number-*INB-174* (“Installation Nucléaire de Base”).

For Protection Important Components and in particular Safety Important Class components (SIC), the French Nuclear Regulation must be observed, in application of the Article 14 of the ITER Agreement.

In such case the Suppliers and Subcontractors must be informed that:



- The Order 7th February 2012 applies to all the components important for the protection (PIC) and the activities important for the protection (PIA).
- The compliance with the INB-order must be demonstrated in the chain of external contractors.
- In application of article II.2.5.4 of the Order 7th February 2012, contracted activities for supervision purposes are also subject to a supervision done by the Nuclear Operator.

For the Protection Important Components, structures and systems of the nuclear facility, and Protection Important Activities the contractor shall ensure that a specific management system is implemented for his own activities and for the activities done by any Supplier and Subcontractor following the requirements of the Order 7th February 2012.

In the framework of this contract, there are activities and components important for the protection of the interests mentioned under Article L.593-1 of the French Environmental Code (public safety, health and sanitation, the protection of nature and of the environment) called respectively PIA and PIC. Design activities on PIC, safety demonstration and safety calculations are considered as a Protection Important Activity as per the Order dated 7 February 2012 relating to the general technical regulations applicable to INB. Moreover, TAPB (civil work and internal systems), for example, are Protection Important Components that are falling under the scope of this contract.

## 15 Appendix 1: Main features of the TAP Building and the TAPB workshop

The figures below are illustrations of the general arrangement and the current 3D model of the TAPB at ground floor, the mechanical workshop and the basement level.

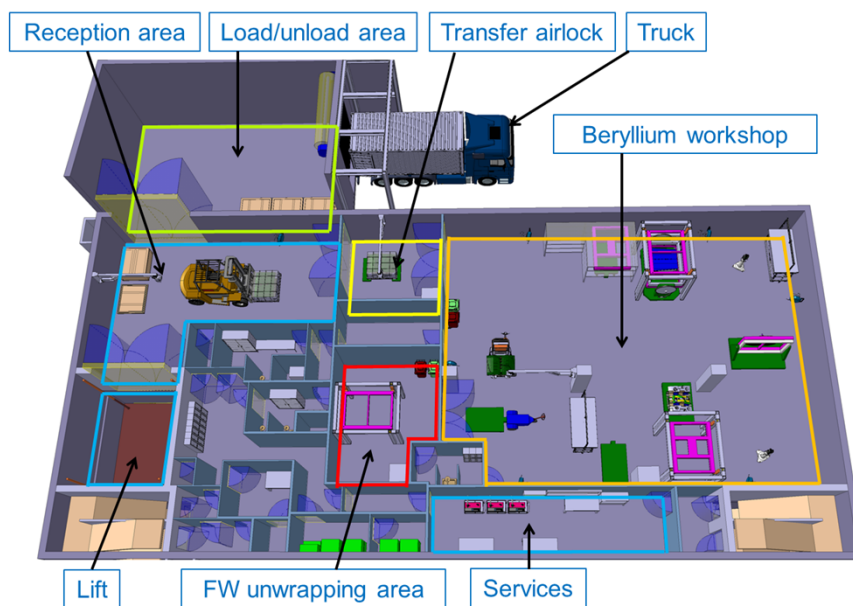

Figure 6: 3D view of the TAPB ground floor

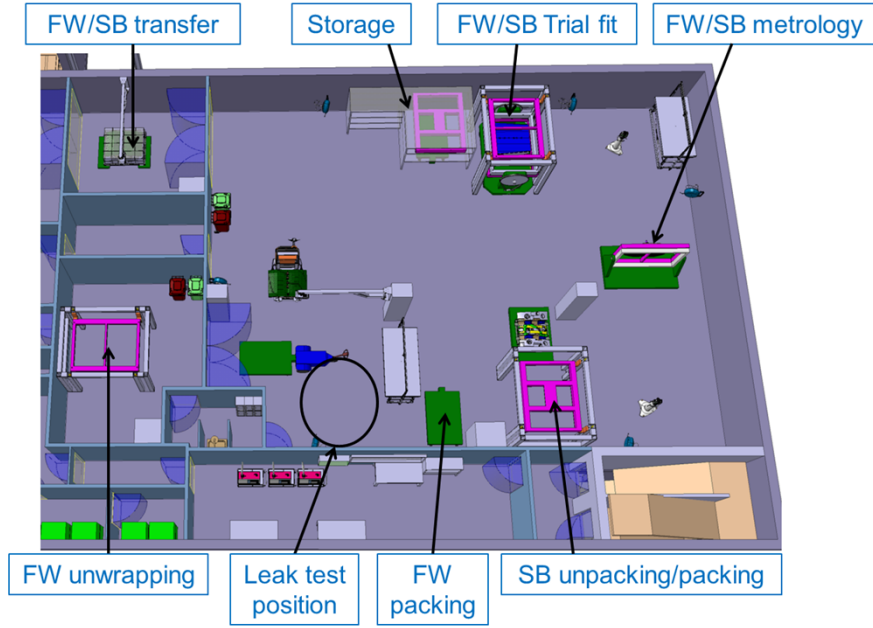

Figure 7: 3D view of the TAPB workshop

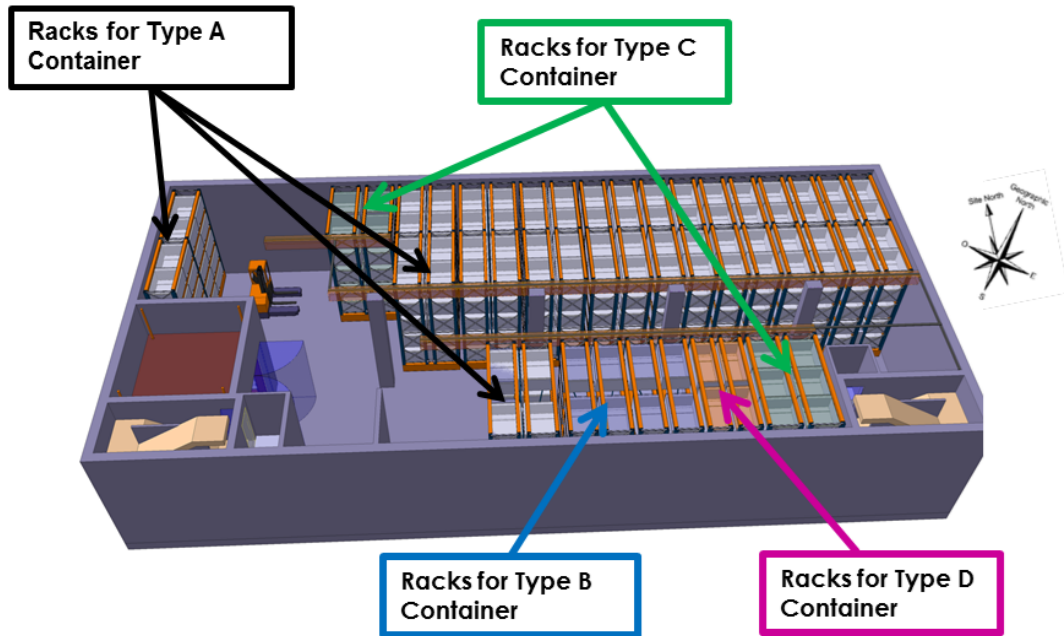

Figure 8: 3D view of the TAPB basement